

Rorke Data Desktop (RDD™) Storage RDD500, 1000, 2000 and 4000 Series User Manual

Rev. 2.0



Rorke Data, Incorporated • 9700 W. 76th Street • Eden Prairie, MN 55344
800.328.8147 • 952.829.0300 • Fax 952.829.0988

Rorke Data Europe • Nautilusstraat 5a 7821 AG Emmen–The Netherlands
31.0.591651165 • Fax 31.0.591651185

Rorke Data Italy • Via Angelo Carrara 210 • 16147 Genova Italia
+39 (0) 10.373.3127/7 • Fax +39 (0) 10.377.6606

www.rorke.com

Rorke Data, Incorporated • 9700 W. 76th Street • Eden Prairie, MN 55344
800.328.8147 • 952.829.0300 • Fax 952.829.0988

Rorke Data Europe • Nautilusstraat 5a 7821 AG Emmen–The Netherlands
31.0.591651165 • Fax 31.0.591651185

Rorke Data Italy • Via Angelo Carrara 210 • 16147 Genova Italia
+39 (0) 10.373.3127/7 • Fax +39 (0) 10.377.6606

www.rorke.com

Copyright © 1999 by Rorke Data, Inc.

All Rights Reserved. No part of this publication may be reproduced, transmitted, transcribed, stored in a retrieval system, or translated into any language, in any form or by any means, electronic, mechanical, photocopying, recording or otherwise, without the expressed written permission of Rorke Data, Inc.

Printed in the USA

Part Number

Revision A

Rorke Data

9700 West 76 th Street

Eden Prairie, MN 55344

Tel: 612-829-0300, USA 800-326-8147

Fax: 612-829-0988

Ad graphics group

europe b.v.

A Subsidiary of Rorke Data

Nautilusstraat 5a AF Emmen

P.O. Box 2246 7801 CE Emmen

The Netherlands

Tel: +31.5910-40900 Fax +31.39-43883

Disclaimer

Rorke Data, Inc. reserve the right to make changes to this manual and the equipment described herein without notice. Rorke Data has made all reasonable efforts to ensure that the information in this manual is accurate and complete. However, Rorke Data shall not be liable for any technical or editorial errors or omissions made herein or for incidental, special, or consequential damage of whatsoever nature resulting from the furnishing of this manual, or operation and performance of equipment with this manual.

Rorke Data Product Support

For current information on Rorke Data products, including updates to the manual and any technical support related concerns, please contact your sales representative or our web page support sections at www.rorke.com Rorke Data's address, phone and fax numbers are at the bottom of the pages in this manual. Use the table on this page to record information about the sales representative for your area.

Sales Representative	Telephone/Fax/Email

5. Appendix B - Common Rorke Data Cables and Terminators

Table 1 - Selection of Rorke Data SCSI Cables and Terminators

Model Number	Description
HGMGMX X=2,3,6,or 20 (ft)	Cable - 68 pin to 68 pin, M-M, Thmbscrw
HHMHMX X=2,3,5,or 6 (ft)	Cable-HD50 pin to HD50 pin, M-M, Thmbscrw
HCMCMX X=2,3,or 6 (ft)	Cable - Cent 50 pin to Cent 50 pin, M-M, Thmbscrw
HGMHMX X=2,3,6,or 9 (ft)	Cable - 68 pin to HD50, M-M, Thmbscrw
HCMHM3 X=3 or 6 (ft)	Cable - Cent 50 pin to HD50 pin, M-M, Thmbscrw
HCMGM3 X=3 or 6 (ft)	Cable - Cent 50 pin to 68 pin, M-M, Thmbscrw
HGMVMX X=6,9, or 12 (ft)	Cable - 68 pin to VHD 68 pin, M-M, Thmbscrw
SDSMACX X=2,3,6, or 10 (ft)	Cable - DB25 pin, to DB25 pin, M-M, Thmbscrw
TERMCM50-SA	Terminator - Cent 50 pin, single-ended, active
TERMCM50-SP	Terminator - Cent 50 pin, single-ended, passive
TERMCM50-DP	Terminator - Cent 50 pin, differential, passive
TERMHM50-SA	Terminator - HD50 pin, single-ended, active
TERMGM68-DA	Terminator - 68 pin, differential, active
TERMGM68-SA	Terminator - 68 pin, single-ended, active

Table of Contents

1.RORKE DATA DESKTOP (RDD)PRODUCT FAMILY	1
1.1 BEFORE YOU BEGIN	1
2.General Description	2
2.1 INDICATOR LED 'S	2
2.2 POWER SUPPLY	2
2.3 RDD SCSI ID SWITCH	2
2.4 PROPER COOLING AND FANS	3
2.5 CABLES	3
2.6 REMOVABLE DRIVES	4
2.6.1 Unit Number Indicator	4
2.6.2 Key Lock/Drive Power Switch for Removable Devices	4
2.6.3 Activity Indicator	5
2.6.4 Removing the Drive Carrier	5
3.INSTALLING THE DRIVE ONTO THE COMPUTER SYSTEM	5
3.1 VERIFY CONTENTS OF THE PACKAGE	5
3.2 CONNECTING THE RDD UNIT TO YOUR COMPUTER SYSTEM	7
4.APPENDIX A -FEATURES,SPECIFICATIONS,AND LAYOUT	8
4.1 FEATURES AND PHYSICAL LAYOUT	8
4.1.1 Rorke Data 's RDD 500 Series	8
4.1.2 Rorke Data 's RDD 1000 Series	8
4.1.3 Rorke Data 's RDD 2000 Series	9
4.1.4 Rorke Data 's RDD 4000 Series	9
4.2 PHYSICAL AND ELECTRICAL SPECIFICATIONS	10
4.3 ESD PROTECTION	10
5.APPENDIX B -COMMON RORKE DATA CABLES AND TERMINATORS	11
Rorke Data Product Support	12

Rorke Data Desktop (RDD) Product Family

1. Product Family

Congratulations on your purchase of a Rorke Data Desktop (RDD) product. The RDD500,1000, 2000, and 4000 Series encompass a wide variety of peripheral storage products including: hard drives, tape, optical, and CD-R devices which are enclosed in one, two, or four bay configurations.

- **Hard Drives** - The RDD hard drives offer a variety of capacity and performance alternatives. Many are available with Ultra SCSI wide or differential interfaces and come in either a fixed or removable configuration.
- **Tape Drives** - AIT and DLT tape drives are available in Ultra SCSI wide or differential interfaces.
- **Optical Drives** - Magneto Optical or LIM-DOW technology with a narrow SCSI (SCSI-1) interface.
- **CD-R** - 4X speed with narrow SCSI interface. Rorke Data also offers peripheral media to support any of the RDD products. Please call 1-800-328-8147 for media requirements.



Figure 2 - RDD1000 Fixed
Note: Also available in removable configuration

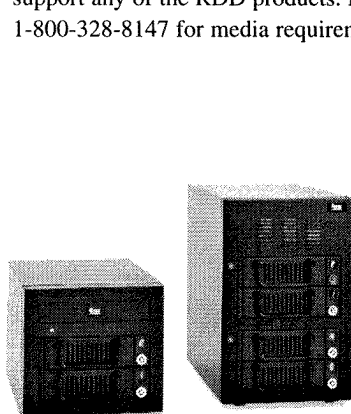

Figure 1 - RDD2000 and RDD4000 Removable

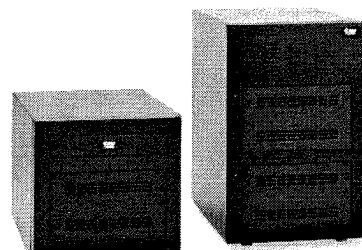

Figure 3 - RDD2000 and RDD4000 Fixed

1.1 Before You Begin

Included with this manual is a Readme First document. To discover the power and ease of using this product, please read all manuals thoroughly. This manual presents a general description of the components of your RDD subsystem and provides instructions to guide you through the installation process. It supplements other material that came

4.2 Physical and Electrical Specifications

Following is a table displaying the physical and electrical specifications of the RDD products.

Physical Dimensions	RDD500 Series	RDD1000 Series	RDD2000 Series	RDD4000 Series
Height	2.1in / 53.3mm	2.7in / 68.5mm	7.3in / 183mm	11.4in
Width	6.5in / 165.1mm	9.7in / 246.4mm	7.5in / 190mm	7.3in
Depth	8.0in / 203.2mm	10in / 245mm	12in / 305mm	12.7in
Weight	2.8lbs / 1.3kg	4lbs / 1.8kg	9bs / 4.1kg	
Electrical	Typical/Peak	Typical/Peak	Typical/Peak	Typical/Peak
Power Supply	17W / 32W	40w / 60w	65w / 150w	(2)50w/788w
+5	1A / 2A	3A / 5A	3.5A / 5A	3.5A
+12	1A / 1.5A	2A / 4A	4A / 11A	4A/5.5A max cont.
AC Input	96-276VAC: 50-60 HZ	96-276VAC: 50-60 HZ	96-276VAC: 50-60 HZ	90-264VAC: 50-60 HZ
Fan/CFM	40mm 13-18CFM	60mm 13-18CFM	80mm 26-32CFM	4.75"

4.3 ESD Protection

Rorke Data adheres to strict procedures to prevent electrostatic discharge (ESD) from compromising the quality of your product. ESD is the direct discharge of a charged conductor which can create damage or latent failures of electronic components. All drive components are susceptible. To minimize potential damage, please avoid opening the enclosure and exposing components. If it is necessary to open the enclosure ground yourself to the drive ideally using a wrist strap. As a general rule, remember that you and the drive must be grounded to avoid static discharge damage.

4.1.3 Rorke Data's RDD 2000 Series

Features

- Accommodates one 5.25" full height or two half height 3.5" or 5.25" drives
- AC input receptacle
- AC power on / off switch located on back panel
- DC harness
- 80mm fan
- Green 'power on' LED indicator
- Amber 'drive activity' LED indicator
- SCSI I/O data cable for up to two drives with two externally mounted Centronics 50-pin, HD50, or 68-pin style connectors
- 1 or 2 SCSI ID push button switches with 2.54mm drive mount header Audio jack cut-outs are plugged
- Black as standard
- UL, CSA, TUV & CE approvals

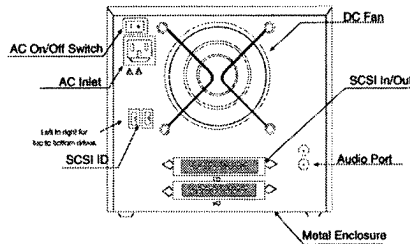

Figure 12 - Back View RDD 2000

4.1.4 Rorke Data's RDD 4000 Series

Features

- Accommodates two 5.25" full height or four half height 3.5" or 5.25" drives
- AC input receptacle
- AC power on / off switch located on back panel
- DC harness
- 4.75" fan
- (2) 50W power supplies
- Green 'power on' LED indicator
- Amber 'drive activity' LED indicator
- SCSI I/O data cable for up to four drives with two externally mounted Centronics 50-pin, HD50, or 68-pin style connectors
- 4 SCSI ID push button switch
- Black as standard
- UL, CSA, TUV & CE approvals

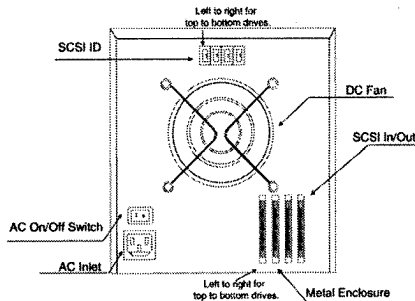

Figure 13 - Back View RDD 4000

with your computer system. Make sure you have all appropriate documentation before beginning the installation process. If you feel uncomfortable with any of the procedures described in this manual, please contact a qualified Rorke Data Service Representative.

2. General Description

Each RDD device comes equipped with indicator LED's, a power supply, a fan, and internal cables and has been tested in our world-class integration facility. If the device was ordered to be removable, it will come preconfigured with the removability features.

2.1 Indicator LED's

The RDD product line all contain power and drive indicator lights on the front panel for ease of diagnosis. "Power on" status is a green LED. Each drive will contain an LED to indicate drive activity.

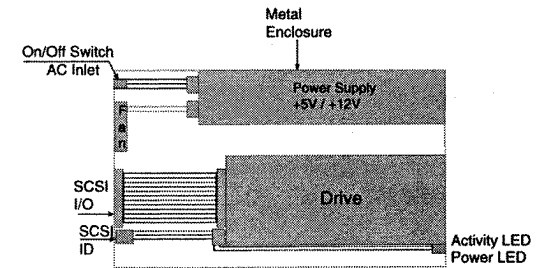

Figure 4 - Top View RDD 1000

2.2 Power Supply

The power supply unit provides both +5V and +12V. The peak power rating on +12V output supports all RDD product applications. Please refer to Appendix A for electrical specifications of your RDD unit.

2.3 RDD SCSI ID Switch

The RDD SCSI ID is an address that is assigned to each SCSI device to uniquely identify the device on the SCSI network (address numbers include 0 through 7 for narrow, 8 bit protocol or 0 through 15 for wide, 16 bit protocol). If your computer network

is already equipped with SCSI devices then some ID's may already be reserved. SCSI ID 7 and SCSI ID 15 are usually reserved for the host controller in narrow or wide networks respectively, and SCSI ID 0 is typically already selected for an internal drive. Refer to the computer system documentation for additional information.

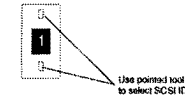

Figure 5 - SCSI ID Switch

The RDD SCSI ID switch(es) is located on the back of the unit. The push button selector can be selected with the tip of a pen or a straightened paper clip.

2.4 Proper Cooling and Fans

The enclosure has been designed with a fan unit to direct airflow around critical drive components and to provide proper cooling. It is important to note that the enclosure should be placed in an area where ambient air temperatures do not exceed drive temperature specifications. Please review operating temperature ranges for your specific drive(s).

2.5 Cables

All internal cables have been installed in your RDD device and have been tested for connectivity at Rorke Data's testing facility.

External cables which connect the RDD device to your computer system have not been provided unless specifically ordered.

The SCSI protocol and external cable connections have followed an evolutionary migration path. Shown are diagrams of the more common SCSI connections that you may encounter when connecting your RDD device to your computer system.

Rorke Data offers cables in a variety of configurations to ensure connectivity. These are high-quality cables to provide system integrity for data-intensive work flow environments.

Please refer to Appendix B for a list of Rorke Data Cables and Terminators.

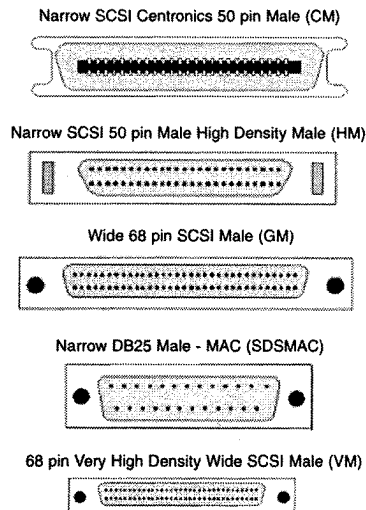

4. Appendix A - Features, Specifications, and Layout

4.1 Features and Physical Layout

4.1.1 Rorke Data's RDD 500 Series

Features

- Accommodates one 1" high 3.5" drive
- AC input receptacles
- AC power on/off switch located on back panel
- DC harness
- Metal enclosures
- Green 'power on' LED indicator
- Drive activity indicator
- 1 each - 40mm fan
- SCSI I/O data cable for up to two drives with two externally mounted Centronics 50-pin, HD50, or 68-pin style connectors
- Black as standard
- UL, CSA, TUV, CE approval

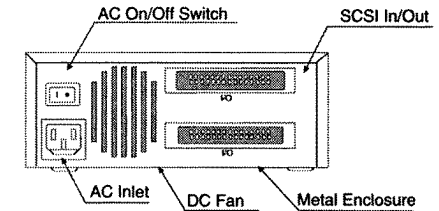

Figure 10 - Back View RDD500

4.1.2 Rorke Data's RDD 1000 Series

Features

- Accommodates one 5.25" half height or one 3.5" drive
- AC input receptacle
- AC power on/off switch located on back panel
- DC harness
- Green 'power on' LED indicator
- Amber 'drive activity' LEDs
- 1 each fan 60mm fan
- SCSI I/O data cable for up to two drives with two externally mounted Centronics 50-pin, HD50, or 68-pin style connectors
- SCSI ID switch with 2.54mm drive mount header
- Audio jack cut-outs are plugged
- Black as standard
- UL, CSA, TUV, CE approval

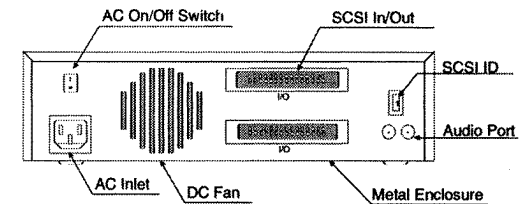

Figure 11 - Back View RDD1000

3.2 Connecting the RDD Unit to Your Computer System

1. Power down your computer system. You may leave it plugged in for grounding purposes.
2. Select the SCSI ID. Insert a small-tipped object, i.e. ball-point pen, fine gauge screw-driver, etc. Depress either the + or the - key to select an unassigned number
 - between 1-6 for narrow
 - between 1-15 for wide
3. Verify that your SCSI cable(s) contains the proper connectors (see section 2.5 for cable descriptions).
4. Connect one end of your SCSI cable to the rear of the device and lock it into place.
5. Connect the other end to either your computer system or another peripheral device, depending on your configuration (see figures 8 and 9). Be careful to select the correct port. Your computer system may have multiple SCSI ports for third party board(s) or the native CPUs board. Refer to your computer system owner's manual or call Rorke Data for assistance.
6. If your RDD product is the last device on the SCSI network, then it will require the appropriate termination for the I/O connector. Refer to Figure 8 for a typical single SCSI connection and Figure 9 for a daisy-chained SCSI connection. Only the last device in the SCSI chain requires termination.
7. Power up your RDD device and allow it to spin up (approx. 1 minute). When spin up is complete, power up your CPU. Verify that the power LED is on. For RDD units shipped with an active terminator, verify that the active LED is illuminated.
8. Once the RDD device is on, the activity LED will be illuminated when accessed by the computer system. Depending on the type of interface, this LED will either flash or glow steadily during communication.
9. Depending on your system, the RDD product will need to be initialized. Consult your system manual for the proper routine to do this. Once this procedure is complete your new RDD unit is ready to be used by your computer system.

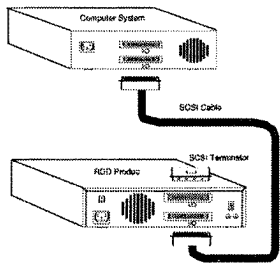

Figure 8 - Typical Single SCSI Connection

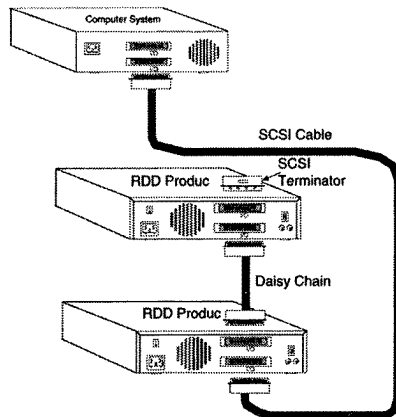

Figure 9 - Daisy Chain SCSI Connection

2.6 Removable Drives

The RDD hard drive products may be fitted with an option of removability. These quick-disconnect bays are provided with individual key locks located on the front of the frame which prevent accidental or unwanted removal of drives. The frame portion of the bay is fix-mounted while the disk portion of the bay remains easily removable. To disconnect the drive carrier, simply use the key to unlock the drive, slide the drive out and insert the replacement drive. Use the key again to lock the drive in place. The key also provides the electrical power switch to the drive. We recommend that the chassis power be turned off before replacing any drive.

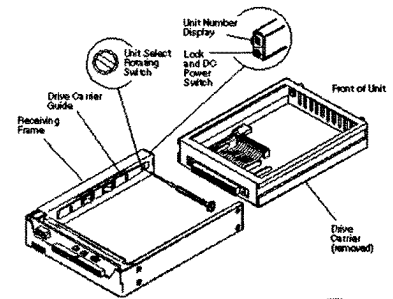

Figure 6 - Drive Carrier and Receiver for Removable Drives

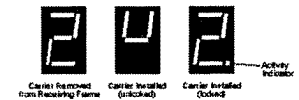

Figure 7 - Receiving Bay Select Display Conditions
The number "2" display is for illustration purposes only. It can be any valid Unit ID number. However, the letter "u" (above middle) will appear as illustrated.

2.6.1 Unit Number Indicator

The Unit Number Indicator displays the physical address of the device. If the device is removable, the Unit Number is displayed if the carrier is installed and locked in the receiving bay or if the carrier is removed from the receiving bay. If the carrier is installed but not locked in the receiving bay, a "u" will be displayed to indicate an unlocked condition (see figure 7). The unit number is changeable by an address switch located on the rear of the cabinet.

2.6.2 Key Lock/Drive Power Switch for Removable Devices

The Key Lock/Drive Power Switch performs three functions. The key lock assures proper seating of the device carrier within the receiving frame. It turns device carrier power on and off. It prevents unauthorized removal or installation of the carrier. For the computer to access data on the disk drive, the key must be turned counter-clockwise to the locked position. As an option, the key can be attached to the locking mechanism.

2.6.3 Activity Indicator

The activity indicator LED is a small dot next to the Unit Number which illuminates to show when the host is accessing the computer. Depending on the type of interface, this LED will either flash or glow steadily during communication.

2.6.4 Removing the Drive Carrier

1. Verify that power is turned on to the RDD receiving bay by turning on the computer and RDD device. A number should appear in the unit display window if the carrier is locked in place.
2. Unlock the carrier in the receiving bay. Unless the spin down/up timer has been displayed, the unit number will begin flashing, indicating that the drive is spinning down.

DO NOT REMOVE THE CARRIER FROM THE RECEIVING BAY WHILE THE UNIT NUMBER IS FLASHING.

Warning: Unlocking the carrier unit switches off DC power to the drive. Since disk drives require a short amount of time to spin down, allow about 15 seconds before pulling the carrier out of the receiving bay to avoid possible damage to the drive.

3. A "u" will be displayed once the drive has completed spin down and is ready to be removed from the receiving bay. The indicator will return to the SCSI ID number when the carrier is removed from the receiving bay.

3. Installing the Drive onto the Computer System

Installing the RDD unit onto your Computer System is an easy process. Please follow the steps indicated.

3.1 Verify Contents of the Package

The Rorke Data Desktop products are shipped to you in packaging designed to provide protection and prevent damage during shipment. Your unit was inspected before and during the packing procedure and tested in our world-class integration facility. As you unpack, check the container and the unit itself for any signs of damage that might have occurred during shipment. Unpack the equipment carefully and inspect the assembly for bent or broken connectors, or other physical damage. Report any damage to the carrier immediately.

If you find evidence of physical damage to the RDD unit, or if you received the wrong model number, please phone the Rorke Data Customer Service Department. A Staff member will issue you a Return Material Authorization (RMA) number to facilitate processing. Rorke Data cannot accept material which does not display an RMA number on the mailing label. Be sure to return the unit and all other contents in its original package.

Before you remove any component from its packaging, be sure to discharge any static electricity by touching a properly grounded object.

Standard Contents of an RDD Series product include:

- Drive
- Manual Terminator
- Driver software

Note: Device drivers for MAC-based computer systems are included. Device drivers for Win/NT based computer systems are pre-installed on your computer.